



## ZDM150

### 150W LED Zigbee Dimmer Module

- Easy push button setup
- Trailing/Leading Edge
- No Neutral required
- Soft start feature
- Silent & flicker free
- Self Recovering Thermal Fuse
- Short Circuit & Overload Protection
- Manual dimming possible via a connected Retractive Switch(s)
- Support IOS or Android for wireless
- Compatible with most leading Zigbee Gateways

<b>Operating Voltage</b>	240V ac
<b>Nominal Operating Freq.</b>	50 Hz
<b>Dimming Technique</b>	Trailing & Leading Edge Phase Control
<b>Compliance</b>	BS EN 60669-2-1

Load Symbol	Compatible Loads	Max Load	Min Load
	Dimmable LED lighting	150W TE 100W LE	2W
	240V Incandescent & Halogen lamps	150W TE 100W LE	2W
	Low voltage lighting with electronic transformers	150W TE 100W LE	2W

Multi-Gang Switch De-Rating Chart				
1 Gang	2 Gang	3 Gang	4 Gang	5 Gang
150W	127W	105W	82W	60W

#### COMPATIBLE WITH MOST ZIGBEE GATEWAYS, INCLUDING;

- Alexa echo plus (with zigbee hub built in)
- Philips Hue
- Samsung
- Raspberry
- Conbee
- Homey
- Tuya zigbee hub (Not Tuya customized function)
- Home assistant

#### IMPORTANT NOTE:

Some driverless products can still operate with a small amount of residual current present, such as LED strip lighting etc, it may be necessary to fit a bypass device to allow this product to dim completely to off.

#### ZIGBEE SETUP INSTRUCTIONS:

##### NETWORK PAIRING MODE

1. Remove the device from any previous Zigbee network if it has already been bound to one, otherwise any pairing attempt will fail. Please refer to the section titled "Network Factory Reset Procedure" for factory reset procedure.
2. From your Zigbee controller or Hub interface, choose add lighting device or dimmer device and enter Pairing Mode as instructed by the controller.
3. Double press setup button to activate the network pairing mode (The indicator light will flash blue) Network pairing mode will remain active for 15 minutes, repeat step 2 if this times out before setup has completed.

**Note:** Depending on your OS, this device may be automatically added to your device list.

4. The blue indicator light will stop flashing and remain lit for 10s when pairing is successful, the device will now appear in your controller's menu and can be controlled through controller or hub interface.

**Note:** The blue indicator light will remain on for 2 seconds to warn that the dimmer has previously been paired to a Zigbee network and that this pairing attempt has failed.

##### TOUCHLINK BETWEEN ZIGBEE REMOTE AND DEVICE (One device only, no hub required)

**Note:** Please make sure the device and remote are not part of any existing Zigbee network.

1. Short press setup button 4 times.
2. The indicator light will flash green to show the device is in touchlink commissioning mode. This mode will remain active for 180 seconds before timing out, repeat this step if time-out occurs.
3. Bring the remote or touch panel within 10cm of the dimmer device.
4. Set the remote or touch panel into Touchlink commissioning. (Please refer to the corresponding remote or touch panel manual for the correct procedure for this).

5. The connecting lights will start flashing to indicate the pairing processing. Once paired both the connecting lights and the green indicator light will stop flashing and you can control the lights by the remote.

##### TOUCHLINK BETWEEN ZIGBEE REMOTES AND DEVICE (Up to 30 remotes, Hub required)

**Note:** Please make sure the device and remote have already been added to your zigbee network.

1. Short press setup button 4 times.
2. The indicator light will flash green to show the device is in touchlink commissioning mode. This mode will remain active for 180 seconds before timing out, repeat this step if time-out occurs.
3. Bring the remote or touch panel within 10cm of the dimmer device.
4. Set the remote or touch panel into Touchlink commissioning. (Please refer to the corresponding remote or touch panel manual for the correct procedure for this).

**NOTE:** For Philips Hue Bridge & Amazon echo plus, add remote and device to network first, then Touchlink.

##### FIND AND BIND MODE

**Note:** Please make sure the device and remote have already been added to your zigbee network.

1. Press the setup button 6 times and the indicator light will start flash yellow. This mode will remain active for 180 seconds before timing out, repeat this step if time-out occurs.
2. Set the remote or touch panel into find and bind mode, and enable it to find and bind initiator. (Please refer to the corresponding remote or touch panel manual for the correct procedure for this).
3. There shall be some indication on the remote or touch panel that the device has bound successfully.

##### NETWORK FACTORY RESET PROCEDURE

Press and hold the setup button for over 5 seconds until the indicator shows a red light.

**Note:** All configuration will be reset after the device is reset or removed from the network. This does not include min/max and dimming mode setting).

## DIMMER SETUP INSTRUCTIONS

**NOTE:** Manual control of the On/Off function and dimming up and down can also be achieved with a connected Retractive Switch, or multiple (parallel) Retractive Switches. Please refer to example circuit diagrams to the right of this text for some connection examples of this option.

A fast click of the Retractive Switch will turn the lamp (or Load) on and off, holding the switch will alternately dim the lamp up or down, release the switch when desired lamp brightness has been achieved.

The minimum/maximum level and dimming mode can be manually adjusted by following the procedures below.

**NOTE:** This product is supplied with a minimum level already set, if this does not work well with your situation, please perform a Factory Reset before setting a minimum level to suit your setup.

### SETTING THE MINIMUM LEVEL

1. Whilst on, adjust dimmer to your desired minimum brightness.
2. Push the rear setup button 3 times within 2 seconds.
3. The LEDs will step up and down in brightness once to confirm the setting has been saved.

### SETTING THE MAXIMUM LEVEL

1. Whilst on, adjust dimmer to your desired maximum brightness.
2. Push the rear setup button 5 times within 3 seconds.
3. The LEDs will step up and down in brightness once to confirm the setting has been saved.

### FACTORY RESET FOR MIN/MAX BRIGHTNESS

1. Please note this factory reset will reset all the min and max brightness settings.
2. Whilst on, push the rear setup button 7 times within 5 seconds.
3. The LEDs will step up and down in brightness three times to confirm that the min/max setting has been cleared.

### CHANGING THE DIMMING MODE

The default mode of the dimmer is Trailing Edge, but it can be put into Leading Edge if required. Please ensure that you know the correct mode for your lamp.

1. Whilst on, push the rear setup button 9 times within 5 seconds.
2. The LEDs will step up and down in brightness twice to confirm the setting has been changed to Leading Edge mode.

**NOTE:** To switch back to Trailing Edge mode, just repeat the process again, the LEDs will step up and down once to show the dimmer is back in Trailing Edge mode.

## SIMPLIFIED DECLARATION OF CONFORMITY

Enkin declares that the 150W Zigbee Dimmer Module is in compliance with SI 2017 No. 1206 TELECOMMUNICATIONS The Radio Equipment Regulations 2017.

The full text of the UK declaration of conformity is available at the following internet address: [https://enkin.com/ZDM150\\_DoC/](https://enkin.com/ZDM150_DoC/)

## ONE-WAY PUSH RETRACTIVE SWITCH WIRING OPTION

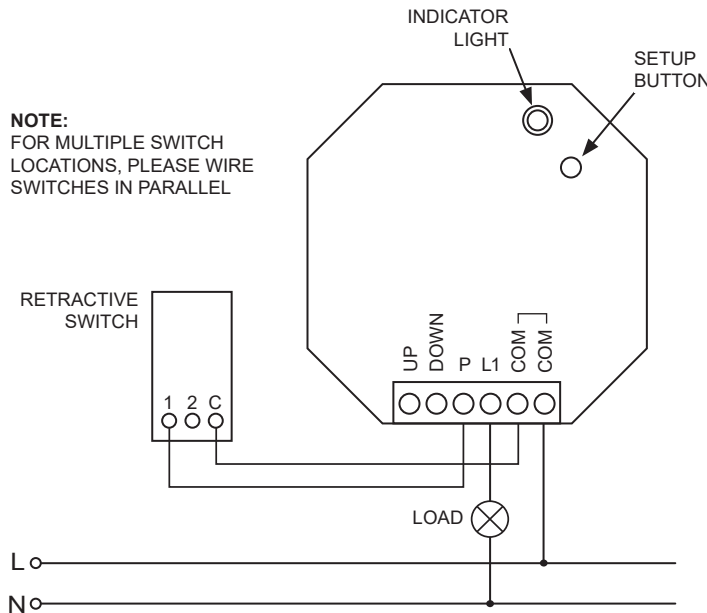

## TWO-WAY & OFF PUSH RETRACTIVE SWITCH WIRING OPTION

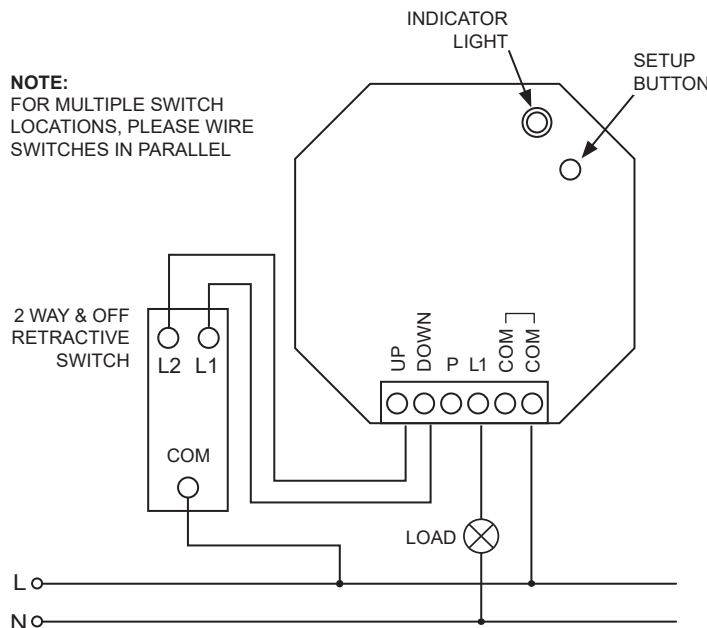

## ⚠️ ⚠️ WARNING

### RISK OF ELECTRIC SHOCK

- Hazardous voltage and electrical current may be present at the wire leads of this product even when the device is switched off.
- Lock out and tag the input circuit before accessing the wiring connections.
- This device must be installed by a qualified and experienced electrician in accordance with applicable current electrical regulation.
- To comply with all safety standards, the product must be used only for the purpose described in this instruction and must be installed in accordance with the wiring rules and regulation in the location where it is installed.
- There are no user serviceable parts inside the product. Failure to follow these instructions can result in death or serious injury.

### EQUIPMENT DAMAGE HAZARD

- Install the device according to instructions in this document.
- Pay attention to the specifications and wiring diagrams related to the installation.
- Do not use this product for any other purpose than specified in this instruction.
- The product is suitable for indoor use only.
- Apply IEC60898-1 compliant 250V~ 6A MCB as an overload protective device.

### ENVIRONMENTAL PROTECTION

Waste electrical products should not be disposed of with household waste. Please recycle where facilities exist. Check with your local authority or retailer for recycling advice.

## LEGAL DISCLAIMER

The installation of electrical products is inherently dangerous and can lead to serious injury or death. The products we sell MUST be installed by a qualified and experienced electrician in accordance with applicable current electrical regulation. Any advice, guidance or other information provided by Enkin on their website or within any of our publications cannot completely anticipate your situation and common sense must prevail. Products need to be checked prior to installation and regularly for damage, wear and tear. Products should be returned and not used if in any doubt of their integrity.

Electrical rated loads and limits of a given product should NEVER be exceeded at any time. The electricity supply should always be isolated at its source (Distribution Board) before attempting any installation or maintenance.

No advice or information, whether oral or written, obtained by you from us or through the service, our employees, consultants and/or retailers shall create any warranty not expressly made herein.

You agree to assume all and any risk resulting from the utilisation of information provided by Enkin. You also expressly agree not to hold us responsible for any damage, personal injury, death or loss resulting from your use of our information, service or regulatory compliant products.

Enkin is a registered trademark and trading name of Trade Ivy Ltd. Registered in England Number: 10809945. Copyright © 2024. All Rights Reserved Trade Ivy Limited, Unit 3C Latham Park, St Blazey Road, Par, PL24 2HY

Scan QR Code for more detailed technical information on this product

[www.enkin.com](http://www.enkin.com)

UK CA CE IP20

